

Pastomaster 180 RTL

Automatic ice-cream mix pasteurizer

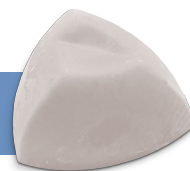

Main features

- Partialization of production capacity from 30 to 180 kg
- Automatic Pasteruization cycle
- Tank capacity from 30 to 180 kg per cycle
- All components in contact with the mix are in stainless steel and polymers food approved
- Mixing from the bottom side that insures full accessibility to the tank
- Tank cover in polymer
- N. 2 taps for mix output

Technical data

DIMENSIONS

Width: 750 mm (L)
Depth: 1060 mm (P)
Height: 1190 mm (H)

CYCLE

180 kg (max)

ELECTRICAL SUPPLY

400/50/3

BEATER MOTOR

2 x 1,1 kW

APPROXIMATE WEIGHTS

Net weight: 370 Kg
Gross weight: 420 Kg

WATER CONDENSER

Water inlet connection: 3/4 gas
Water outlet connection: 3/4 gas

REFRIGERATION SYSTEM

Compressor: 5,5 kW (max)
Refrigerant: R404A

HEATING POWER

15,3 kW (max)

TOTAL MAX POWER

17,5 kW

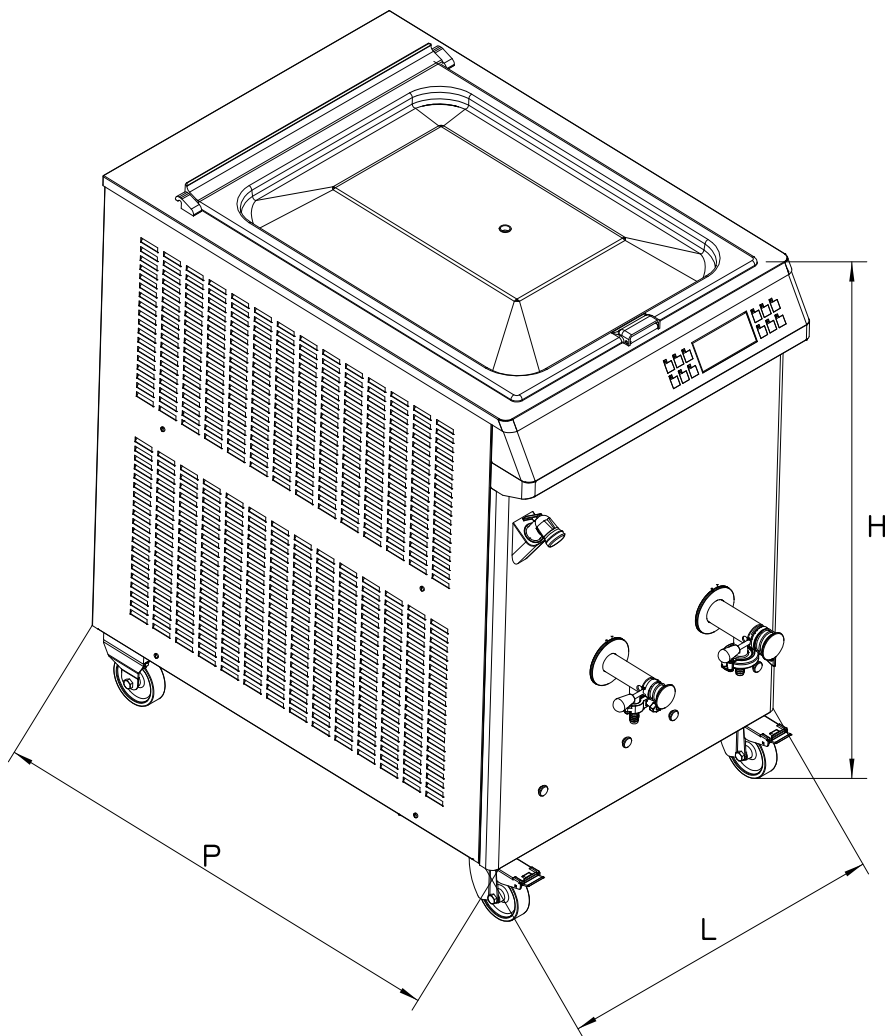

MODEL	Cycle Production *		Electrical supply			Installed power kW	Conden- ser	Dimensions mm			Net Weight Kg
	Min	Max	Volt	Phase	Cycle			Width (L)	Depth (P)	Height (H)	
Pastomaster 180 RTL	30	180	400	3	50	17,5	Water	750	1060	1190	300

* Hourly production can vary with the mix used and operating conditions

Data was collected at 25°C ambient temperature

Due to continuous improvements arising from constant research and development these data are subject to change without notice.



Via Emilia, 45
40011 Anzola Emilia BOLOGNA, Italy
Tel. +390516505111
carpigliani.com